

FLEXIDOME IP corner 9000 MP

www.boschsecurity.com



BOSCH

Invented for life



- ▶ Corner-mount, no-grip design for maximum safety
- ▶ 1.5 MP resolution for sharp images
- ▶ Views an entire small room, including directly beneath
- ▶ 940 nm illuminator for covert night vision to 9 m (30 ft)
- ▶ IP65 water resistance

The FLEXIDOME corner 9000 MP is a vandal-resistant, corner-mount camera featuring a no-grip, anchor-free design. The high resolution 1440 x 1080p images and the integrated infrared illumination allow 24/7 effective professional networked surveillance in high risk, vandal-prone applications under any ambient lighting conditions, even completely dark rooms. The ultra-wide lens enables the camera to view the entirety of a small room, including the floor beneath the camera. The camera is impossible to grip or hang from, providing maximum safety for applications such as waiting rooms, elevators and psychiatric care rooms.

System overview

Corner-mount, vandal-resistant design

The innovative design allows a perfectly flush fit into the corner of a room that protects against even the most brutal attempt to destroy, detach or disable the camera. The sharp 45° angle hides all wiring and delivers complete coverage of a 4.5 x 4.5 m (15 x 15 ft) room, including below the camera itself. The camera has no anchor points for maximum safety in environments with at-risk individuals.

Infrared illumination

The camera harnesses the power of infrared illumination to deliver outstanding images day or night. Infrared-emitting LEDs achieve covert, effective night vision for the most advanced level of night vision performance available today. With the intensity-adjustable infrared LEDs, foreground hotspots and underexposed backgrounds are eliminated.

True day/night switching

The camera incorporates mechanical filter technology for vivid daytime color and exceptional night-time imaging under infrared illumination while maintaining sharp focus under all lighting conditions. The camera also features outstanding spectral response in the near infrared field for excellent active-infrared night vision.

Intelligent Dynamic Noise Reduction reduces bandwidth and storage requirements

The camera uses Intelligent Dynamic Noise Reduction which actively analyzes the contents of a scene and reduces noise artifacts accordingly. The low-noise image and the efficient H.264 compression technology provide clear images while reducing bandwidth and storage by up to 50% compared to other H.264 cameras. This results in

reduced-bandwidth streams that still retain a high image quality and smooth motion. The camera provides the most usable image possible by cleverly optimizing the detail-to-bandwidth ratio. Area-based encoding is another feature which reduces bandwidth. Compression parameters for up to eight user-definable regions can be set. This allows uninteresting regions to be highly compressed, leaving more bandwidth for important parts of the scene. The average typical optimized bandwidth (for firmware 5.8) in bits/s for various image rates is shown in the table:

IPS	1080p	VGA
30	1200	600
15	955	478
7.5	711	355
5	568	284
3	388	194

1440 x 1080p resolution with multiple streams

The camera has a 1440 x 1080p resolution at 30 images per second (ips). The innovative multi-streaming feature delivers various H.264 streams together with an M-JPEG stream. These streams facilitate bandwidth-efficient viewing and recording as well as integration with third-party video management systems.

Regions of interest and e-PTZ

Two Regions of Interest (ROI) can be user defined. The remote electronic pan, tilt and zoom (e-PTZ) controls allow you to select specific areas of the parent image. These regions produce separate streams for remote viewing and recording. These streams, together with the main stream, allow the operator to separately monitor the most interesting part of a scene while still retaining situational awareness.

Easy installation

No focus or pan/tilt adjustments are required as the camera, with its wide angle lens, provides complete coverage of a 4.5 x 4.5 m (15 x 15 ft) room. Power for the camera can be supplied via a Power-over-Ethernet (IEEE 802.3af) compliant network cable connection. With this configuration, only a single cable connection is required to view, power, and control the camera. Using PoE makes installation easier and more cost-effective, as cameras do not require a local power source.

The camera can also be supplied with power from +12 VDC or 24 VAC power supplies. To increase system reliability, the camera can be simultaneously connected to both PoE and +12 VDC/24 VAC supplies. Additionally, uninterruptible power supplies (UPS) can be used, which will allow continuous operation, even during a power failure. For trouble free network cabling, the cameras support Auto-MDIX.

Two-way audio and audio alarm

Two-way audio allows the operator to communicate via an external audio line input and output. Audio detection can be used to generate an alarm if needed.

Tamper and motion detection

A wide range of configuration options is available for alarms signaling camera tampering. A built-in algorithm for detecting movement in the video can also be used for alarm signaling.

Edge recording

The internal MicroSD card slot supports up to 2 TB (SDXC) of storage capacity. A microSD card can be used for local alarm recording. Pre-alarm recording in RAM reduces recording bandwidth on the network, or – if microSD card recording is used – extends the effective life of the storage medium.

Cloud-based facilities

The camera supports time-based or alarm-based JPEG posting to four different accounts. These accounts can address FTP servers or cloud-based storage facilities (for example, dropbox). Video clips or JPEG images can also be exported to these accounts. Alarms can be set up to trigger an e-mail or SMS notification so you are always aware of abnormal events.

Access Security

Password protection with three levels and 802.1x authentication is supported. To secure Web browser access, use HTTPS with a SSL certificate stored in the camera. The video and audio communication channels can be independently AES encrypted with 128-bit keys by installing the optional encryption site license.

Complete viewing software

There are many ways to access the camera's video features: using a web browser, with the supplied Bosch Video Client, or with the iPad App. The Bosch Video Client PC surveillance software offers a user-friendly interface to support easy installation and configuration, and is supplied completely free-of-charge. It provides easy live viewing of multiple cameras, playback, forensic search and export.

Video security App

The Bosch Video Security iPad App has been developed to fully utilize our Dynamic Transcoding features and enable **Anywhere** access to HD surveillance images, even over low-bandwidth connections. The App, together with the separately available Bosch transcoder, is configured to give you complete control of your camera.

System integration

Bosch IP standard definition and high definition cameras, encoders and analytics work seamlessly with a wide range of security software and recording solutions from Bosch and other industry providers. Through ONVIF conformance, the open availability of Bosch video software development kits and a team

dedicated to special integration and support projects, it is easy to manage Bosch video products within your system design (for details on the Bosch Integration Partner Program, visit ipp.boschsecurity.com).

Applications

- Waiting rooms
- Hospital recovery rooms
- Psychiatric care rooms
- Vandal-prone areas

Certifications and approvals

Standards	IEC 62471
	EN 60950-1
	UL 60950-1
	CAN/CSA-C22.2 NO. 60950-1
	EN 50130-4
	EN 50130-5
	FCC Part15 Subpart B, Class B
	EMC directive 2004/108/EC
	EN 55022/24 class B
	VCCI J55022 V2 / V3
	AS/NZS CISPR 22 (equal to CISPR 22)
	ICES-003 class B
	EN 50121-4
	EN 50132-5-2; IEC 62676-2-3
Product certifications	CE, FCC, UL, cUL, C-tick, CB, VCCI
Ingress protection	IP65
Impact protection	IK10

Region	Certification
Europe	CE
USA	UL

Installation/configuration notes

Dimensions

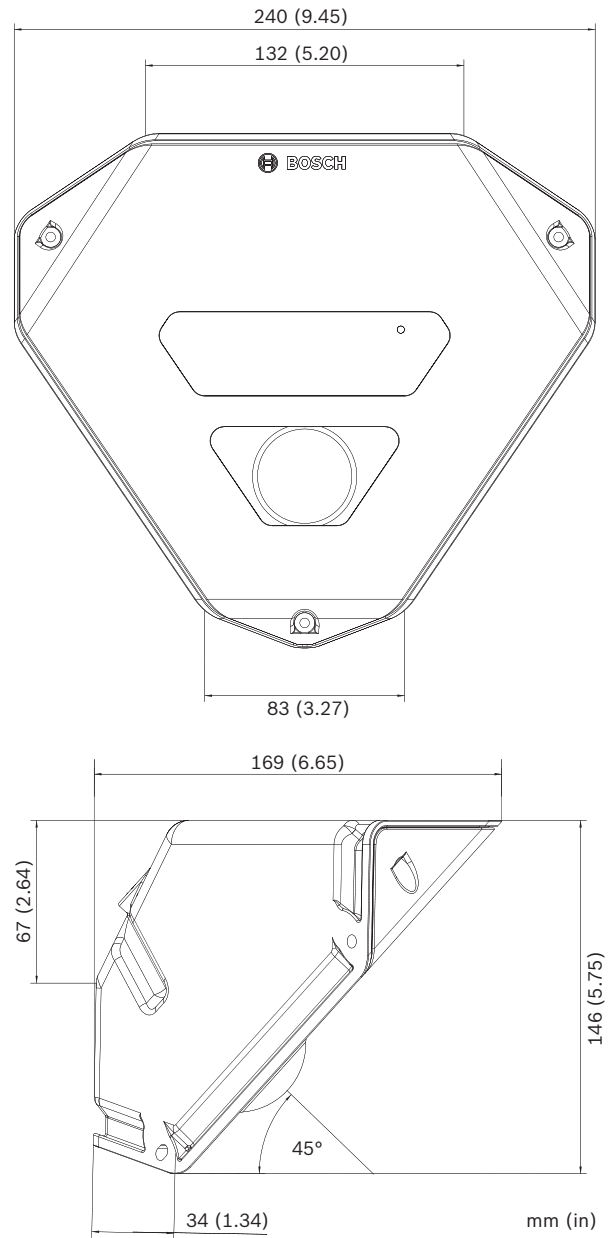

Technical specifications

Input voltage	+12 VDC / 24 VAC or Power-over-Ethernet (48 VDC nominal)
Power consumption	8.4 W max. (12 VDC, PoE) 10.8 VA max. (+24 VAC)
PoE	IEEE 802.3af (802.3at Type 1) Power level: Class 3

Video

Sensor type	1/2.7-inch CMOS
Resolution	1440 x 1080
Sensitivity (3200 K, reflectivity 89%, 30IRE, F2.0)	0.61 lx (color) 0.0 lx (IR)
Dynamic range	69 dB
True Day/Night	Auto, Color, Monochrome
Shutter speed	Automatic Electronic Shutter (AES) Fixed 1/30 (1/25) to 1/15000
SD Video resolution	VGA, QVGA
Video compression	H.264 MP (Main Profile); M-JPEG
Max. frame rate	30 ips (M-JPEG frame rate can vary depending on system loading)
Video Settings	Video watermarking, Alarm mode stamping, Image mirror, Image flip, Contrast, Saturation, Brightness, White balance, Sharpness level, Contrast enhancement, Backlight Compensation, Privacy Mask, Motion detection, Tamper alarm, Upright mode, Pixel counter

Night vision

IR LEDs	3 high efficiency LEDs, 940 nm
IR coverage	9 m (30 ft)

Lens

Lens type	Fixed 2.0 mm, F2.0
Lens mount	Board mounted
Horizontal field of view	121°
Vertical field of view	91°

Connection

Analog video out (for installation only)	2.5 mm jack connector (1 Vpp CVBS, NTSC)
Alarm input	0 to 3.3 VDC, low active
Alarm output	60 VDC or 60 VAC (max), load current: 1 A (max)

Audio

Audio input	Line in 3.5 mm mono connector 0.707 Vrms, impedance 20k Ohm (typical)
Audio output	Line out 3.5 mm mono connector 0.707 Vrms, impedance 10k Ohm (typical)

Audio communication	Two-way, full duplex
Audio compression	AAC, G.711, L16 (live and recording)

Local Storage

Internal RAM	10 s pre-alarm recording
Memory card slot	Supports up to 32 GB microSDHC / 2 TB microSDXC card. (An SD card of Class 6 or higher is recommended for HD recording)
Recording	Continuous recording, ring recording, alarm/events/schedule recording

Software Control

Unit configuration	Via web browser or PC surveillance software
--------------------	------------------------------------------------

Network

Protocols	IPv4, IPv6, UDP, TCP, HTTP, HTTPS, RTP/RTCP, IGMP V2/V3, ICMP, ICMPv6, RTSP, FTP, Telnet, ARP, DHCP, SNTP, SNMP (V1, MIB-II), 802.1x, DNS, DNSv6, DDNS, SMTP, iSCSI, UPnP (SSDP), DiffServ (QoS), LLDP, SOAP, Dropbox, CHAP, Digest Authentication.
Encryption	TLS 1.0, SSL, DES, 3DES, AES (optional)
Ethernet	10/100 Base-T, auto-sensing, half/full duplex
Ethernet connector	RJ45
Connectivity	ONVIF Profile S, Auto-MDIX

Mechanical

Dimensions (W x H x D)	240 x 146 x 169 mm (9.45 x 5.75 x 6.65 in.)
Weight	1840 g (4.06 lb) approx.

Environmental

Operating temperature	-10 °C to +50 °C (14 °F to +122 °F)
Storage temperature	-30 °C to +60 °C (-22 °F to +140 °F)
Humidity	20% to 90% relative humidity (non condensing)

Ordering information**FLEXIDOME IP corner 9000 MP**

High-performance integrated infrared IP corner-mount camera. No-grip; IP65; IK10; PoE; IDNR; ROI ; H.264 quad-streaming; free viewing Apps; cloud services; fixed 2 mm lens; day/night; 1440x1080p; audio/motion detect; privacy mask

Order number **NCN-90022-F1**

Accessories

S1460 Service/Monitor Cable

2.5 mm jack to BNC video connector cable. 1 m
Order number **S1460**

UPA-2420-50 Power Supply

Power supply for cameras. 220 VAC, 50 Hz In; 24 VAC, 20 VA Out
Order number **UPA-2420-50**

UPA-2430-60 Power Supply

Power supply for camera. 120 VAC, 60 Hz; 24 VAC, 30 VA Out
Order number **UPA-2430-60**

NCA-CMT-GF FLEXIDOME corner 9000 Grey faceplate

Gray faceplate (RAL 9006) with LED window and transparent bubble
Order number **NCA-CMT-GF**

Software Options

BVIP AES 128 Bit Encryption

Site licence for BVIP AES 128-bit encryption. Enables encrypted communication between BVIP devices and management stations
Order number **MVS-FENC-AES**

Represented by:

Americas:

Bosch Security Systems, Inc.
130 Perinton Parkway
Fairport, New York, 14450, USA
Phone: +1 800 289 0096
Fax: +1 585 223 9180
security.sales@us.bosch.com
www.boschsecurity.us

Europe, Middle East, Africa:

Bosch Security Systems B.V.
P.O. Box 80002
5617 BA Eindhoven, The Netherlands
Phone: + 31 40 2577 284
Fax: +31 40 2577 330
emea.securitysystems@bosch.com
www.boschsecurity.com

Asia-Pacific:

Robert Bosch (SEA) Pte Ltd, Security Systems
11 Bishan Street 21
Singapore 573943
Phone: +65 6571 2808
Fax: +65 6571 2699
apr.securitysystems@bosch.com
www.boschsecurity.asia

China:

Bosch (Shanghai) Security Systems Ltd.
201 Building, No. 333 Fuquan Road
North IBP
Changning District, Shanghai
200335 China
Phone +86 21 22181111
Fax: +86 21 22182398
www.boschsecurity.com.cn

America Latina:

Robert Bosch Ltda Security Systems Division
Via Anhanguera, Km 98
CEP 13065-900
Campinas, Sao Paulo, Brazil
Phone: +55 19 2103 2860
Fax: +55 19 2103 2862
latam.boschsecurity@bosch.com
www.boschsecurity.com